

Service on Sinamics converters

Instructions for replacing/updating the power unit control electronics (CIB/CIM)

Valid for the drive unit types: Sinamics S120 chassis format
Sinamics S150
Sinamics G150
Sinamics G130

Notes: Before you start the upgrade, read the prerequisites for the upgrade in Section I.
The required resources for an upgrade are summarized in Section II.

You must observe the safety instructions in the Operating Instructions!

Contents:

I. Hardware – prerequisites and general information

- a.) Control Unit CU320 version
- b.) Notes
- c.) Revisions/Author

II. Required spare parts/tools

- a.) Tools
- b.) Replacing the control electronics module CIB with CIM

III. Replacing the control electronics with a new version (replacing CIB with CIM)

- a.) Preparatory steps:
- b.) Replacing the control board (CIB with CIM)
- c.) Recommissioning 500 V + 690 V devices

IV. Replacing the new control electronics module (CIM with CIM)

V. Connector layout on the control electronics module

- a.) Connector layout on old CIB:
- b.) Connector layout on new CIM:
- c.) Assignment order numbers CIM and IPD:

I. Hardware – prerequisites and general information

a.) Control Unit CU320 version

Firmware Versions from V2.4 require a Control Unit CU320, Version C or higher.

You can check the version of your Control Unit CU320 on the type plate of the Control Unit CU320:

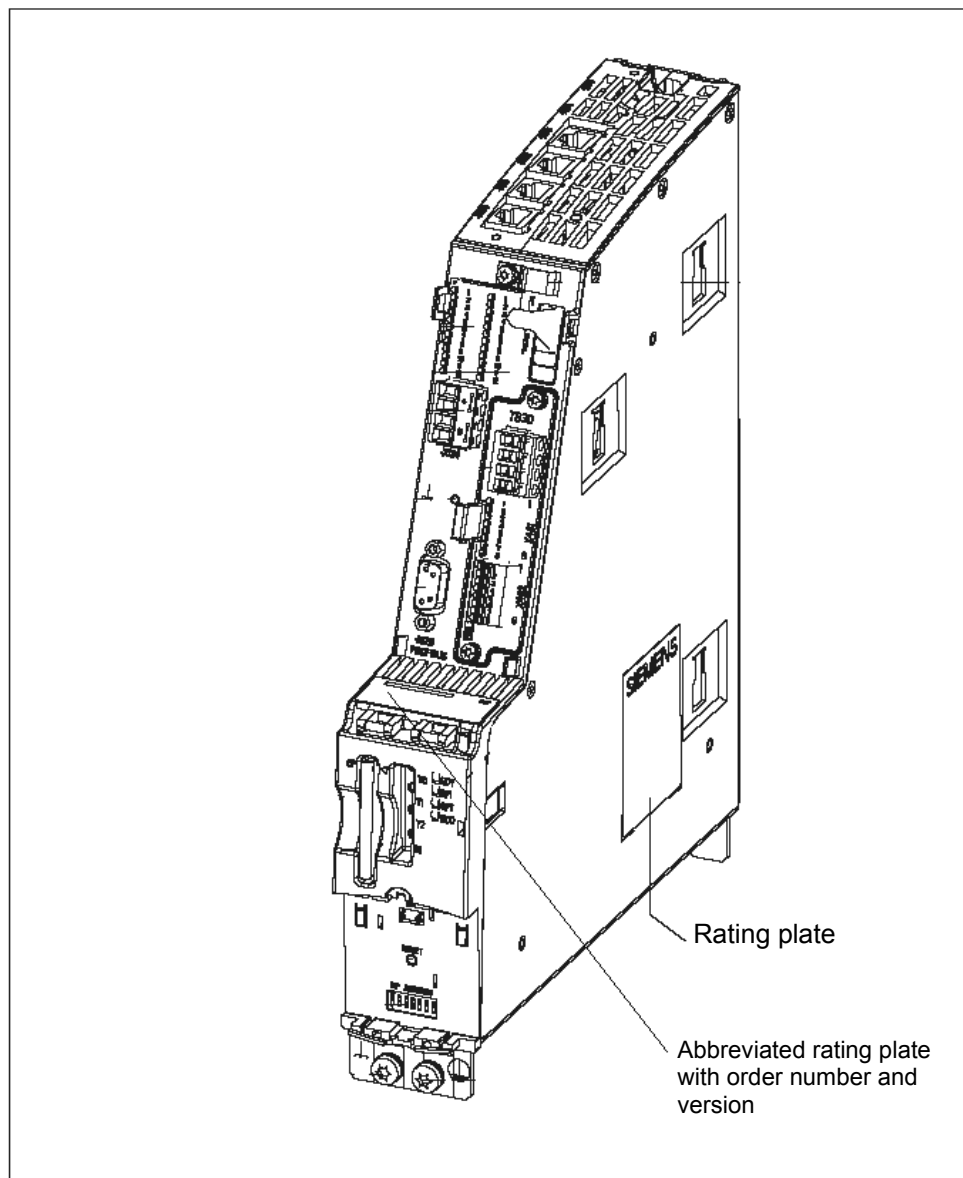

Fig. 1: CU320: Type plate with version data

b.) Notes

It is not necessary to backup the parameters using the Starter when replacing the control electronics module.

For 500 V or 690 V devices, it is also important to observe III.c.). It may be necessary to use the STARTER tool, version V4.1.5 or higher.

All of the old control electronics boards (CIB) must be replaced by the new versions (CIM) in units for parallel connection!

In the software 2.6.x. <HF11 there are problems with the line phase failure detection in the voltage classes 500V, 500-690V and 690V on the AC/AC devices G130/G150, the BLM S120 and the water-cooled BLM S120. This is usually indicated in the no-load state by frequent occurrence of the fault "F30011 power unit line phase failure". The only remedy is to upgrade to SW 2.6 HF11 or higher.

Replacement is possible as of device firmware 2.1.

c.) Revisions/Author

Version	Date/Revision	Author
V0.3	20.04.2009	Arne Meyer
V0.4	06.10.2009	Arne Meyer
V0.5	04.02.2011	Arne Meyer
V0.6	21.06.2012	Arne Meyer
V0.7	21.06.2012	Arne Meyer

II. Required spare parts/tools

a.) Tools

- Torx screwdriver set with extension (socket case)
- Flat-bladed screwdriver (for bus connector)
- Anti-static shoes and/or ground wristband to prevent static charges
- Side cutting pliers
- Cable ties, small

b.) Replacing the control electronics module CIB with CIM

- CIM module with order no. 6SL3350-6TK00-0xA0 (x stands for: E = air-cooled, B = liquid-cooled power units)
- IPD metallic connector (depending on type of device, output and voltage)
- New plastic connectors are delivered with the replacement module.

The order numbers for the new CIM module and the suitable IPD connector are listed in chapter V.c.).

III. Replacing the control electronics with a new version (replacing CIB with CIM)

a.) Preparatory steps:

1. Switch off the main voltage and control voltage. Notice: If the converter has a PROFIBUS connection, and it is the last station on the bus, the entire bus may exhibit a fault when the converter is switched off. In this case, the setting of the bus terminator switch must be changed on the predecessor (red slider switch on the connector).
2. Where necessary, remove the EMC shielding panel at the power block (deployment and size depend on the output).
3. If necessary, remove the CU320. The CU is mounted on a support plate that is fastened to the frame on the side above the CU (yellow mark in Fig. 2). The control electronics module is "concealed" behind the CU320 in most cases. Label the connectors on the CU module prior to removal (-X122; -X132). The designations are stamped onto the plate. Remove the fastening screw from the support plate.
4. Loosen the bus connector and remove the connector from the CU. The DRIVE-CLiQ connections (gray cables, X100 – X103) are not coded and must be labelled.



Fig. 2: Removing the CU320 with support plate

b.) Replacing the control board (CIB with CIM)

Some connector designs are compatible with the old modules. They only need to be reconnected. Connectors that must be changed are described in the steps below.

1. Remove the two fastening screws (with yellow marks in Fig. 3) on the support plate of the control electronics module.



Fig. 3: Support plate with old control electronics module (CIB)

2. Slowly withdraw the control electronics slide-in unit. Remove the connectors one-by-one during the process. Make sure that no cables get caught below the support plate. Note the appearance and positions of the connectors X41 and

X42 (see Fig. 3), since these are changed later. The connectors are labelled and also coded. This makes it difficult to interchange them. The fiber-optic cables must not be kinked! The DRIVE-CLiQ connections (gray cables, X400 – X402) are not coded and must be labelled.

3. Changing the X42 connector. The new X42 connector has only 4 poles. The new connector is located on the replacement module. Reconnection: (order for X42 old to X42 new). Pin 5 -> Pin 3, Pin 6 -> Pin 1, Pin 7 -> Pin 4, Pin 8 -> Pin 2.
4. Changing the X41 connector. The X41 connector is coded on the new control electronics module (red lugs in the socket). Remove one "lug" in the connector socket using a knife.
5. Connecting and fastening the 9-pin sub-D current transformer connector in socket X43 of the cast-metal connector (IPD module).



Fig. 4: IPD connector

6. Changing connectors X31 + X32. (black in-line connectors below the fiber-optic connectors.)
7. Insert the new control electronics module. The position of the X41 connector (on the front panel) has been changed slightly in the new design. So it may be necessary to undo the cable harness a little and pull out the appropriate wires.



Fig. 5: New control electronics (CIM)

8. Reinstalling the CU320.
9. Reapply the control voltage of the converter. The two LEDs of the CIM and on the CU may start to flash. In this case, the converter automatically performs a software update for the individual components (as of V2.5). This is indicated through green-read flashing of the LED on the affected component (in this case the CIM) and through slow orange flashing of the RDY-LED on the CU. It can take some time (up to 15 minutes per power unit) to load the new firmware into the components. After the upgrade procedure, the RDY-LED of the CU flashes quickly with an orange light. **After** this, switch the voltage off and on again and reboot. With the G150, the AOP indicates that a power-on reset is required.

c.) Recommissioning 500 V + 690 V devices

The 500 V + 690 V device series was replaced by 500 - 690 V wide voltage devices in the course of development. If the converter incorporated 500 V or 690 V control electronics, it is now necessary to adapted some parameters.

After the electronics power supply is turned on, the drive powers up. The RDY-LED on the CU and the replaced control electronics light up orange. The STARTER tool or the AOP must now be used to change the following parameters in sequence in the the expert list of the CU:

1. p9 = 1 (Device configuration)
2. p9906 = 3 (Minimum: Compares the component class)
3. p9 = 0 (ready).
4. p977 = 1 (Save in non-volatile memory - downloaded at POWER ON)

Then, the LEDs of the components affected changed back to green and the converter is operable again.

The project in the drive retains its original status, except for the modified parameters; this means that the power unit data of the old module are displayed when you go online.

IV. Replacing the new control electronics module (CIM with CIM)

Performing steps III.a.). The replacement described in step III.b.) is carried out without steps 3-5.

V. Connector layout on the control electronics module

a.) Connector layout on old CIB:

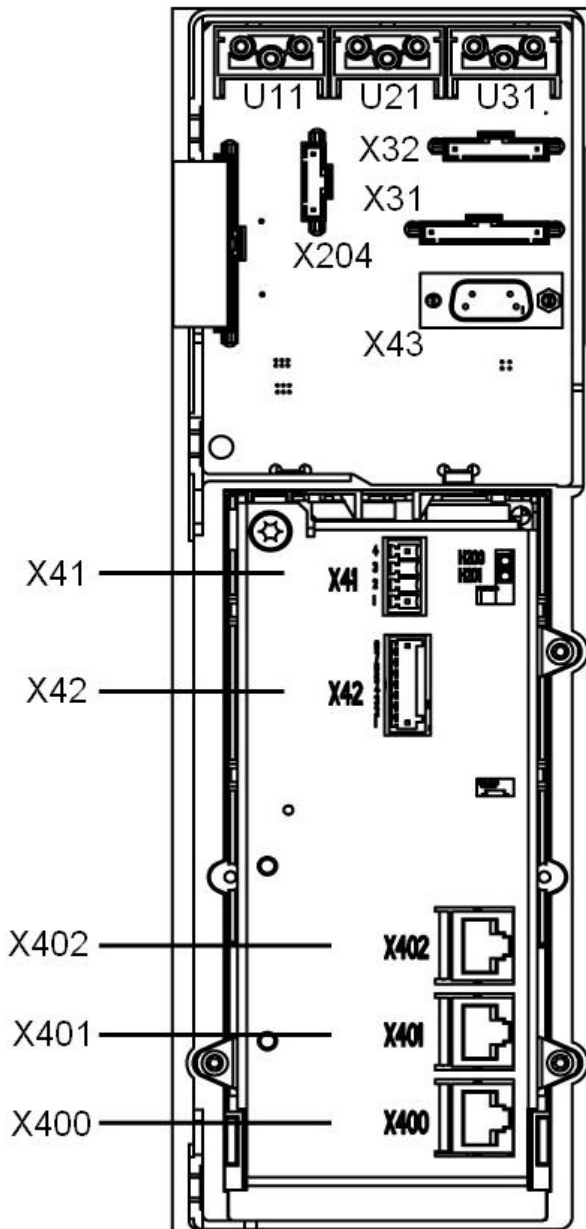

Fig. 6: Connector assignment, front view of old control electronics module (CIB)

Author: 1 DT LD 1 D11, A.Meyer
 Status: July. 2012

A5E02891217A

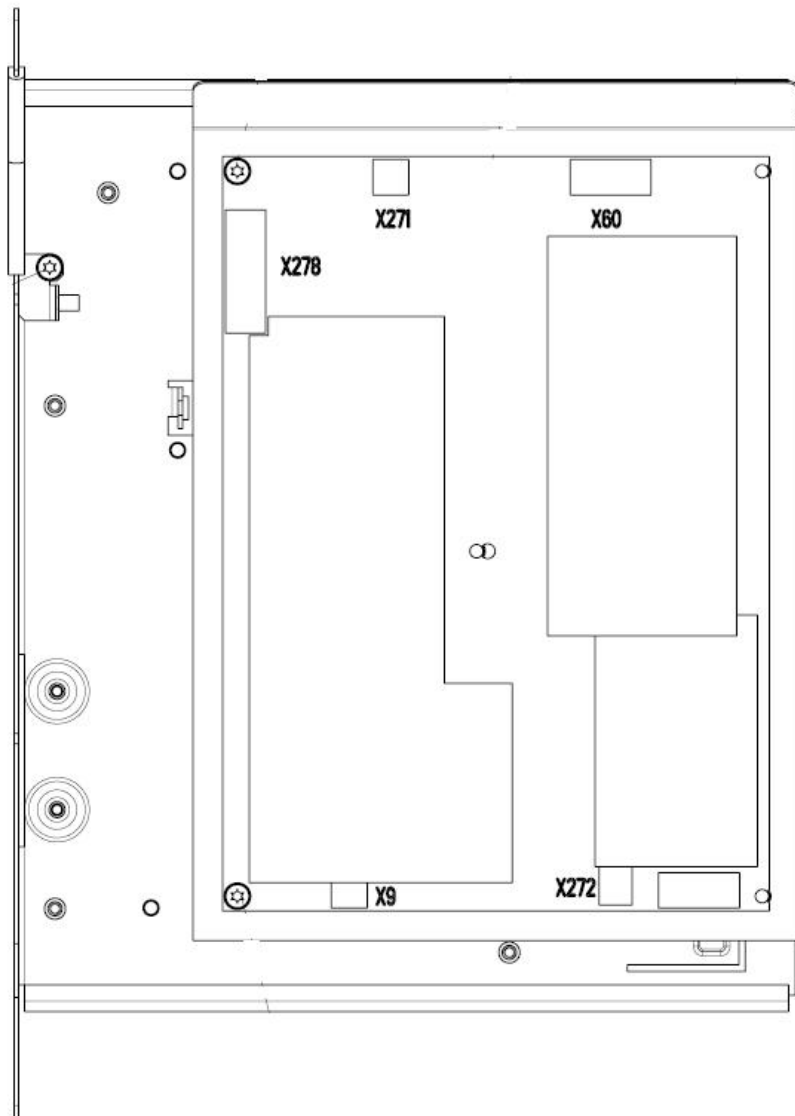

Fig. 7: Connector assignment, side view of old control electronics module (CIB)

b.) Connector layout on new CIM:

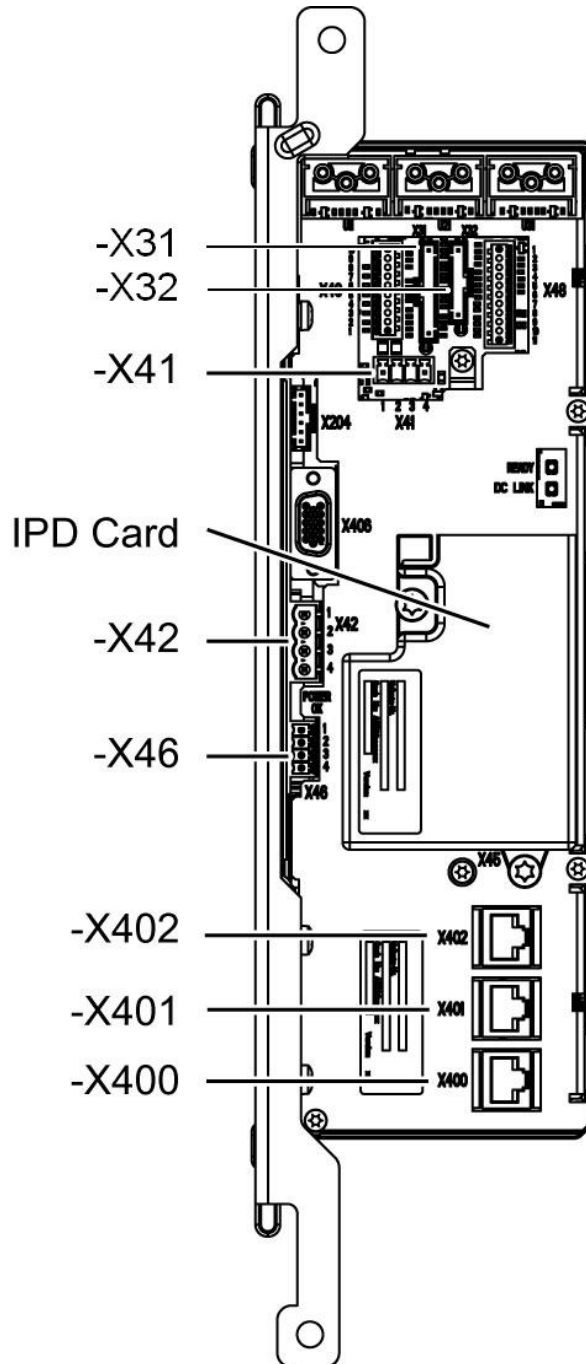

Fig. 8: Connector assignment, front view of new control electronics module (CIM)

Author: 1 DT LD 1 D11, A.Meyer
 Status: July. 2012

A5E02891217A

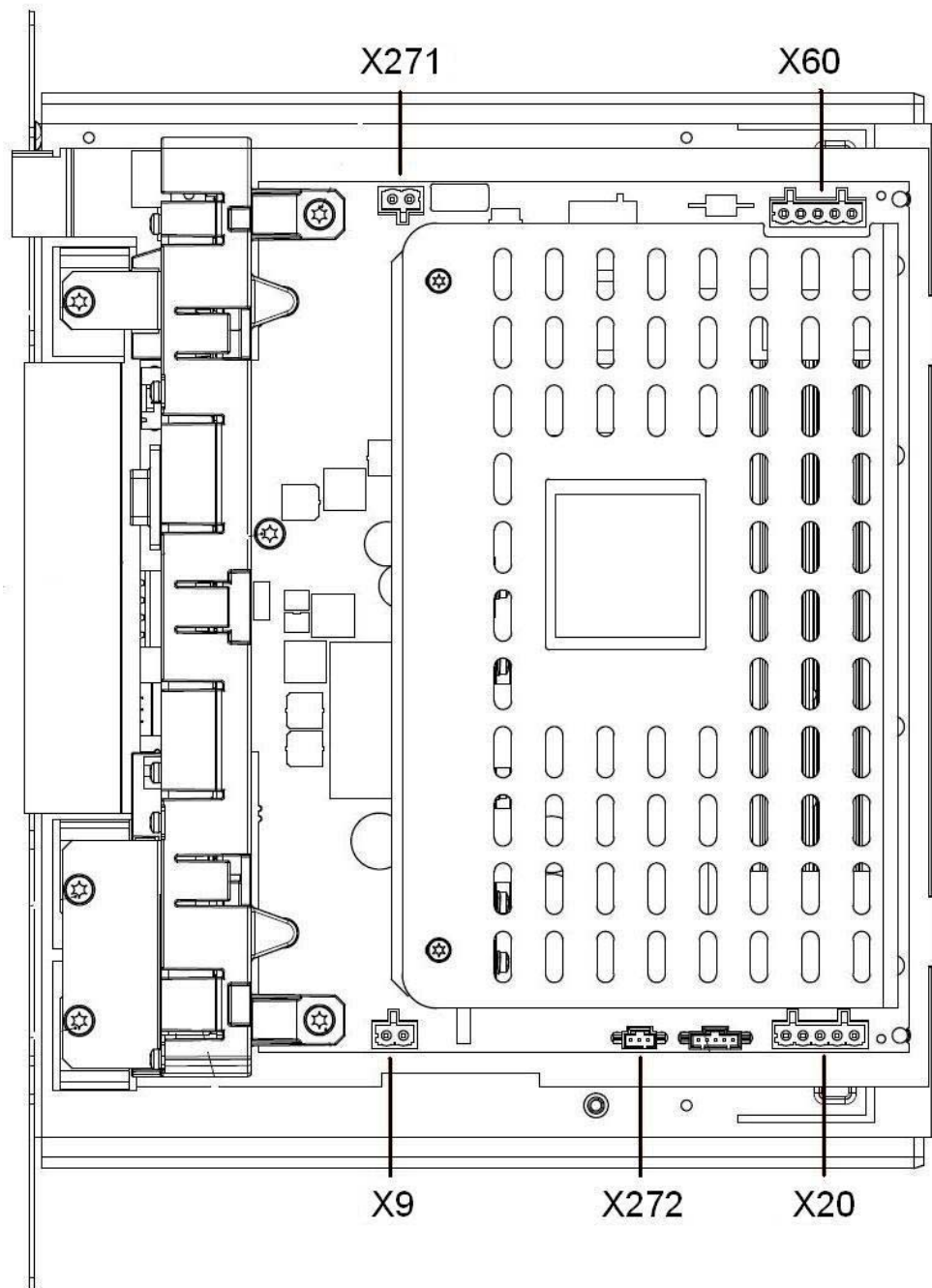

Fig. 9: Connector assignment, side view of new control electronics module (CIM)

Author: 1 DT LD 1 D11, A.Meyer
Status: July. 2012

A5E02891217A

c.) Assignment order numbers CIM and IPD:

The old control electronic (CIB) will be replaced by the new (CIM) and the power unit dependend IPD-card.

MLFB CIB	MLFB CIM	MLFB IPD
6SL3351-6GE32-1AB3	6SL3350-6TK00-0EA0	6SL3351-3AE32-1DB0
6SL3351-6GE32-6AB3	6SL3350-6TK00-0EA0	6SL3351-3AE32-6DB0
6SL3351-6GE33-1AB3	6SL3350-6TK00-0EA0	6SL3351-3AE33-1DB0
6SL3351-6GE33-8AB3	6SL3350-6TK00-0EA0	6SL3351-3AE33-8DB0
6SL3351-6GE35-0AB3	6SL3350-6TK00-0EA0	6SL3351-3AE35-0DB0
6SL3351-6GE36-1AB3	6SL3350-6TK00-0EA0	6SL3351-3AE36-1DB0
6SL3351-6GE37-5AB3	6SL3350-6TK00-0EA0	6SL3351-3AE37-5DB0
6SL3351-6GE38-4AB3	6SL3350-6TK00-0EA0	6SL3351-3AE38-4DB0
6SL3351-6GE41-0AB3	6SL3350-6TK00-0EA0	6SL3351-3AE41-0DB0
6SL3351-6GF31-8AB3	6SL3350-6TK00-0EA0	6SL3351-3AF31-8DB0
6SL3351-6GF32-2AB3	6SL3350-6TK00-0EA0	6SL3351-3AF32-2DB0
6SL3351-6GF32-6AB3	6SL3350-6TK00-0EA0	6SL3351-3AF32-6DB0
6SL3351-6GF33-3AB3	6SL3350-6TK00-0EA0	6SL3351-3AF33-3DB0
6SL3351-6GF34-1AB3	6SL3350-6TK00-0EA0	6SL3351-3AF34-1DB0
6SL3351-6GF34-7AB3	6SL3350-6TK00-0EA0	6SL3351-3AF34-7DB0
6SL3351-6GF35-8AB3	6SL3350-6TK00-0EA0	6SL3351-3AF35-8DB0
6SL3351-6GF37-4AB3	6SL3350-6TK00-0EA0	6SL3351-3AF37-4DB0
6SL3351-6GF38-1AB3	6SL3350-6TK00-0EA0	6SL3351-3AF38-1DB0
6SL3351-6GH28-5AB3	6SL3350-6TK00-0EA0	6SL3351-3AH28-5DB0
6SL3351-6GH31-0AB3	6SL3350-6TK00-0EA0	6SL3351-3AH31-0DB0
6SL3351-6GH31-2AB3	6SL3350-6TK00-0EA0	6SL3351-3AH31-2DB0
6SL3351-6GH31-5AB3	6SL3350-6TK00-0EA0	6SL3351-3AH31-5DB0
6SL3351-6GH31-8AB3	6SL3350-6TK00-0EA0	6SL3351-3AH31-8DB0
6SL3351-6GH32-2AB3	6SL3350-6TK00-0EA0	6SL3351-3AH32-2DB0
6SL3351-6GH32-6AB3	6SL3350-6TK00-0EA0	6SL3351-3AH32-6DB0
6SL3351-6GH33-3AB3	6SL3350-6TK00-0EA0	6SL3351-3AH33-3DB0
6SL3351-6GH34-1AB3	6SL3350-6TK00-0EA0	6SL3351-3AH34-1DB0
6SL3351-6GH34-7AB3	6SL3350-6TK00-0EA0	6SL3351-3AH34-7DB0
6SL3351-6GH35-8AB3	6SL3350-6TK00-0EA0	6SL3351-3AH35-8DB0
6SL3351-6GH37-4AB3	6SL3350-6TK00-0EA0	6SL3351-3AH37-4DB0
6SL3351-6GH38-1AB3	6SL3350-6TK00-0EA0	6SL3351-3AH38-1DB0
6SL3352-6TE36-1AA3	6SL3350-6TK00-0EA0	6SL3352-3AE36-1AA0
6SL3352-6TE37-5AA3	6SL3350-6TK00-0EA0	6SL3352-3AE37-5AA0
6SL3352-6TE38-4AA3	6SL3350-6TK00-0EA0	6SL3352-3AE38-4AA0
6SL3352-6TE41-0AA3	6SL3350-6TK00-0EA0	6SL3352-3AE41-0AA0
6SL3352-6TE41-2AA3	6SL3350-6TK00-0EA0	6SL3352-3AE41-2AA0
6SL3352-6TE41-4AA3	6SL3350-6TK00-0EA0	6SL3352-3AE41-4AA0
6SL3352-6TG28-5AA3	6SL3350-6TK00-0EA0	6SL3352-3AG28-5AC0
6SL3352-6TG31-0AA3	6SL3350-6TK00-0EA0	6SL3352-3AG31-0AC0
6SL3352-6TG31-2AA3	6SL3350-6TK00-0EA0	6SL3352-3AG31-2AC0
6SL3352-6TG31-5AA3	6SL3350-6TK00-0EA0	6SL3352-3AG31-5AC0

Author: 1DT LD 1D11, A.Meyer
Status: July. 2012

A5E02891217A

6SL3352-6TG31-8AA3	6SL3350-6TK00-0EA0	6SL3352-3AG31-8AC0
6SL3352-6TG32-2AA3	6SL3350-6TK00-0EA0	6SL3352-3AG32-2AC0
6SL3352-6TG32-6AA3	6SL3350-6TK00-0EA0	6SL3352-3AG32-6AC0
6SL3352-6TG33-3AA3	6SL3350-6TK00-0EA0	6SL3352-3AG33-3AC0
6SL3352-6TG34-1AA3	6SL3350-6TK00-0EA0	6SL3352-3AG34-1AA0
6SL3352-6TG34-7AA3	6SL3350-6TK00-0EA0	6SL3352-3AG34-7AA0
6SL3352-6TG35-8AA3	6SL3350-6TK00-0EA0	6SL3352-3AG35-8AA0
6SL3352-6TG37-4AA3	6SL3350-6TK00-0EA0	6SL3352-3AG37-4AA0
6SL3352-6TG38-1AA3	6SL3350-6TK00-0EA0	6SL3352-3AG38-1AA0
6SL3352-6TG38-8AA3	6SL3350-6TK00-0EA0	6SL3352-3AG38-8AB0
6SL3352-6TG41-0AA3	6SL3350-6TK00-0EA0	6SL3352-3AG41-0AB0
6SL3352-6TG41-3AA3	6SL3350-6TK00-0EA0	6SL3352-3AG41-3AB0
6SL3352-6TH28-5AA3	6SL3350-6TK00-0EA0	6SL3352-3AG28-5AC0
6SL3352-6TH31-0AA3	6SL3350-6TK00-0EA0	6SL3352-3AG31-0AC0
6SL3352-6TH31-2AA3	6SL3350-6TK00-0EA0	6SL3352-3AG31-2AC0
6SL3352-6TH31-5AA3	6SL3350-6TK00-0EA0	6SL3352-3AG31-5AC0
6SL3352-6TH31-8AA3	6SL3350-6TK00-0EA0	6SL3352-3AG31-8AC0
6SL3352-6TH32-2AA3	6SL3350-6TK00-0EA0	6SL3352-3AG32-2AC0
6SL3352-6TH32-6AA3	6SL3350-6TK00-0EA0	6SL3352-3AG32-6AC0
6SL3352-6TH33-3AA3	6SL3350-6TK00-0EA0	6SL3352-3AG33-3AC0
6SL3352-6TH34-1AA3	6SL3350-6TK00-0EA0	6SL3352-3AG34-1AA0
6SL3352-6TH34-7AA3	6SL3350-6TK00-0EA0	6SL3352-3AG34-7AA0
6SL3352-6TH35-8AA3	6SL3350-6TK00-0EA0	6SL3352-3AG35-8AA0
6SL3352-6TH37-4AA3	6SL3350-6TK00-0EA0	6SL3352-3AG37-4AA0
6SL3352-6TH38-1AA3	6SL3350-6TK00-0EA0	6SL3352-3AG38-1AA0
6SL3352-6TH38-8AA3	6SL3350-6TK00-0EA0	6SL3352-3AG38-8AA0
6SL3352-6TH41-0AA3	6SL3350-6TK00-0EA0	6SL3352-3AG41-0AA0
6SL3352-6TH41-3AA3	6SL3350-6TK00-0EA0	6SL3352-3AG41-3AA0
6SL3353-6TE35-5CA3	6SL3350-6TK00-0EA0	6SL3353-3AE35-5CA0
6SL3353-6TE36-1AA3	6SL3350-6TK00-0EA0	6SL3353-3AE36-1AA0
6SL3353-6TE37-3CA3	6SL3350-6TK00-0EA0	6SL3353-3AE37-3CA0
6SL3353-6TE37-5AA3	6SL3350-6TK00-0EA0	6SL3353-3AE37-5AA0
6SL3353-6TE38-2BA3	6SL3350-6TK00-0EA0	6SL3353-3AE38-2BA0
6SL3353-6TE38-4AA3	6SL3350-6TK00-0EA0	6SL3353-3AE38-4AA0
6SL3353-6TE41-0AA3	6SL3350-6TK00-0EA0	6SL3353-3AE41-0AA0
6SL3353-6TE41-1CA3	6SL3350-6TK00-0EA0	6SL3353-3AE41-1CA0
6SL3353-6TE41-2AA3	6SL3350-6TK00-0EA0	6SL3353-3AE41-2AA0
6SL3353-6TE41-2BA3	6SL3350-6TK00-0EA0	6SL3353-3AE41-2BA0
6SL3353-6TE41-3CA3	6SL3350-6TK00-0EA0	6SL3353-3AE41-3CA0
6SL3353-6TE41-4AA3	6SL3350-6TK00-0EA0	6SL3353-3AE41-4AA0
6SL3353-6TE41-5BA3	6SL3350-6TK00-0EA0	6SL3353-3AE41-5BA0
6SL3353-6TE41-7CA3	6SL3350-6TK00-0EA0	6SL3353-3AE41-7CA0
6SL3353-6TE41-8BA3	6SL3350-6TK00-0EA0	6SL3353-3AE41-8BA0
6SL3353-6TG31-4AA3	6SL3350-6TK00-0EA0	6SL3353-3AG31-4AB0
6SL3353-6TG33-1AA3	6SL3350-6TK00-0EA0	6SL3353-3AG33-1AB0
6SL3353-6TG35-5CA3	6SL3350-6TK00-0EA0	6SL3353-3AG35-5CA0
6SL3353-6TG35-8AA3	6SL3350-6TK00-0EA0	6SL3353-3AG35-8AA0

Author: 1DT LD 1 D11, A.Meyer
 Status: July, 2012

A5E02891217A

6SL3353-6TG37-4AA3	6SL3350-6TK00-0EA0	6SL3353-3AG37-4AA0
6SL3353-6TG38-8CA3	6SL3350-6TK00-0EA0	6SL3353-3AG38-8CA0
6SL3353-6TG41-0AA3	6SL3350-6TK00-0EA0	6SL3353-3AG41-0AA0
6SL3353-6TG41-2CA3	6SL3350-6TK00-0EA0	6SL3353-3AG41-2CA0
6SL3353-6TG41-3AA3	6SL3350-6TK00-0EA0	6SL3353-3AG41-3AA0
6SL3353-6TG41-7CA3	6SL3350-6TK00-0EA0	6SL3353-3AG41-7CA0
6SL3353-6TH31-4AA3	6SL3350-6TK00-0EA0	6SL3353-3AG31-4AB0
6SL3353-6TH33-1AA3	6SL3350-6TK00-0EA0	6SL3353-3AG33-1AB0
6SL3353-6TH34-3BA3	6SL3350-6TK00-0EA0	6SL3353-3AG34-3BA0
6SL3353-6TH35-8AA3	6SL3350-6TK00-0EA0	6SL3353-3AG35-8AA0
6SL3353-6TH36-8BA3	6SL3350-6TK00-0EA0	6SL3353-3AG36-8BA0
6SL3353-6TH37-4AA3	6SL3350-6TK00-0EA0	6SL3353-3AG37-4AA0
6SL3353-6TH41-0AA3	6SL3350-6TK00-0EA0	6SL3353-3AG41-0AA0
6SL3353-6TH41-1BA3	6SL3350-6TK00-0EA0	6SL3353-3AG41-1BA0
6SL3353-6TH41-3AA3	6SL3350-6TK00-0EA0	6SL3353-3AG41-3AA0
6SL3353-6TH41-4BA3	6SL3350-6TK00-0EA0	6SL3353-3AG41-4BA0
6SL3353-6TH41-8BA3	6SL3350-6TK00-0EA0	6SL3353-3AG41-8BA0
6SL3355-6TE32-1AA3	6SL3350-6TK00-0BA0	6SL3355-3AE32-1AA0
6SL3355-6TE32-6AA3	6SL3350-6TK00-0BA0	6SL3355-3AE32-6AA0
6SL3355-6TE33-1AA3	6SL3350-6TK00-0BA0	6SL3355-3AE33-1AA0
6SL3355-6TE35-0AA3	6SL3350-6TK00-0BA0	6SL3355-3AE35-0AA0
6SL3356-6TE32-1AA3	6SL3350-6TK00-0BA0	6SL3356-3AE32-1AA0
6SL3356-6TE32-6AA3	6SL3350-6TK00-0BA0	6SL3356-3AE32-6AA0
6SL3356-6TE33-1AA3	6SL3350-6TK00-0BA0	6SL3356-3AE33-1AA0
6SL3356-6TE35-0AA3	6SL3350-6TK00-0BA0	6SL3356-3AE35-0AA0
6SL3356-6TE36-1AA3	6SL3350-6TK00-0BA0	6SL3356-3AE36-1AA0
6SL3356-6TE38-4AA3	6SL3350-6TK00-0BA0	6SL3356-3AE38-4AA0
6SL3356-6TE41-0AA3	6SL3350-6TK00-0BA0	6SL3356-3AE41-0AA0
6SL3356-6TE41-4AA3	6SL3350-6TK00-0BA0	6SL3356-3AE41-4AA0
6SL3356-6TG31-0AA3	6SL3350-6TK00-0BA0	6SL3356-3AG31-0AA0
6SL3356-6TG31-5AA3	6SL3350-6TK00-0BA0	6SL3356-3AG31-5AA0
6SL3356-6TG32-2AA3	6SL3350-6TK00-0BA0	6SL3356-3AG32-2AA0
6SL3356-6TG33-3AA3	6SL3350-6TK00-0BA0	6SL3356-3AG33-3AA0
6SL3356-6TG35-8AA3	6SL3350-6TK00-0BA0	6SL3356-3AG35-8AA0
6SL3356-6TG38-1AA3	6SL3350-6TK00-0BA0	6SL3356-3AG38-1AA0
6SL3356-6TG41-0AA3	6SL3350-6TK00-0BA0	6SL3356-3AG41-0AA0
6SL3356-6TG41-3AA3	6SL3350-6TK00-0BA0	6SL3356-3AG41-3AA0
6SL3357-6TE35-0AA3	6SL3350-6TK00-0BA0	6SL3357-3AE35-0AA0
6SL3357-6TE37-4BA3	6SL3350-6TK00-0BA0	6SL3358-3AE37-4BA0
6SL3357-6TE38-4AA3	6SL3350-6TK00-0BA0	6SL3357-3AE38-4AA0
6SL3357-6TE41-2BA3	6SL3350-6TK00-0BA0	6SL3358-3AE41-2BA0
6SL3357-6TE41-7BA3	6SL3350-6TK00-0BA0	6SL3358-3AE41-7BA0
6SL3357-6TG34-2BA3	6SL3350-6TK00-0BA0	6SL3358-3AG34-2BA0
6SL3357-6TG35-8AA3	6SL3350-6TK00-0BA0	6SL3357-3AG35-8AA0
6SL3357-6TG37-3BA3	6SL3350-6TK00-0BA0	6SL3358-3AG37-3BA0
6SL3357-6TG41-3AA3	6SL3350-6TK00-0BA0	6SL3357-3AG41-3AA0
6SL3357-6TG41-3BA3	6SL3350-6TK00-0BA0	6SL3358-3AG41-3BA0

Author: 1DT LD1D11, A.Meyer
 Status: July, 2012

A5E02891217A

6SL3357-6TG41-7BA3	6SL3350-6TK00-0BA0	6SL3358-3AG41-7BA0
--------------------	--------------------	--------------------